

Continuous Form Tool

System

TRUMPF

Technical Information

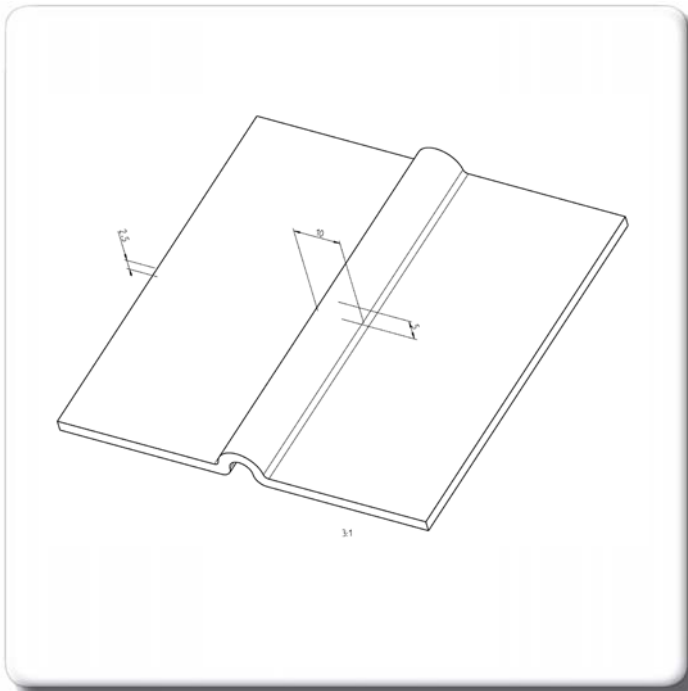

Data:

This tool was produced for machine type

Boschert (ECCO-Line)

Sheet thickness $s = 2,5 \text{ mm}$

Sheet material St 1203

General information

Form-down Tool.

Tool direction: approx. 5 mm/hit

Date: 14.02.2005

Yours PASS Punch & Die Inc.

This information is the property of PASS PUNCH & DIE INC. and must not be copied or otherwise given to other persons without written consent.