

Produktkatalog 01/2009-A

Werkzeugsystem

FINN-POWER/LVD Multitool

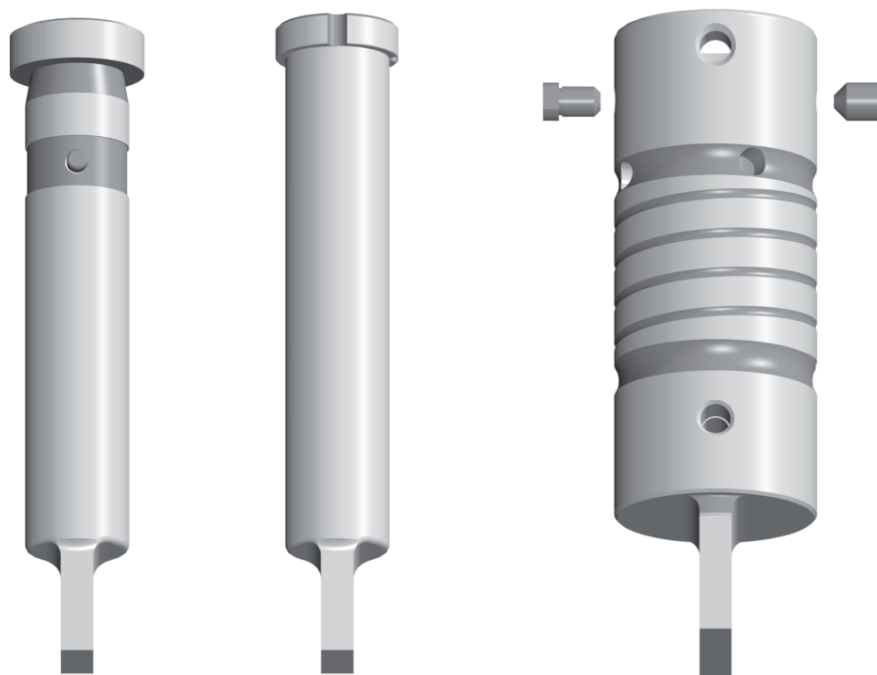



System

FINN-POWER/LVD

MT24Ri-8

MT24i-8

MT20i-8

	Pos.-Nr.	Art.-Nr.	Preis in €
Stempel*			
Rund	1	413111	
Quadrat	1	413112	
Rechteck	1	413113	
Langloch	1	413114	
*schleifbare Kontur	1	41311G	
*erodierbare Kontur	1	41311E	
Abstreifer			
Rund	2	415111	
Quadrat	2	415112	
Rechteck	2	415113	
Langloch	2	415114	
*schleifbare Kontur	2	41511G	
*erodierbare Kontur	2	41511E	
Matrize			
Rund	3	414111	
Quadrat	3+4	414112	
Rechteck	3+4	414113	
Langloch	3+4	414114	
*schleifbare Kontur	3+4	41411G	
*erodierbare Kontur	3+4	41411E	

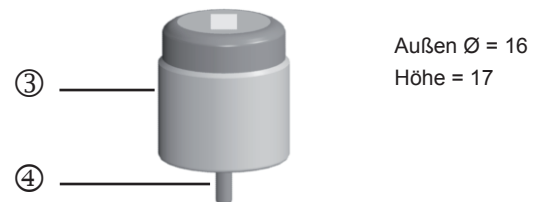
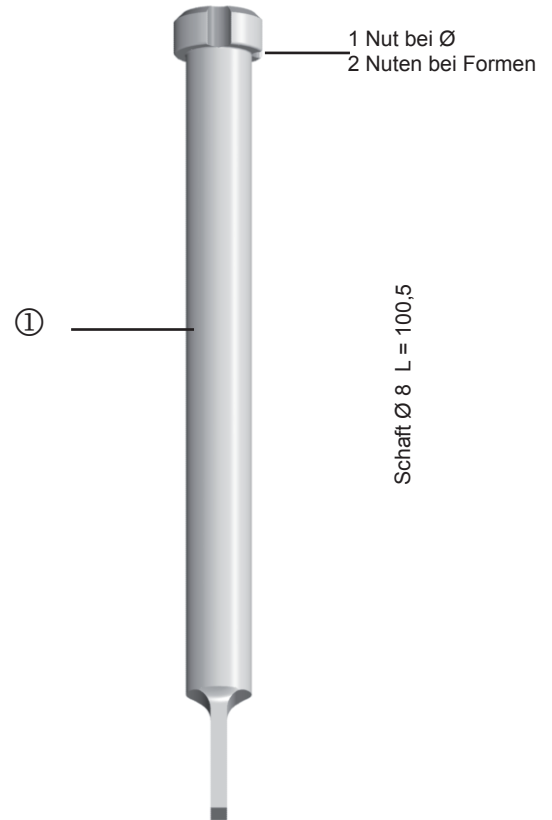

Werkzeug-Aufpreise:	
Stempel	TICN Beschichtung T-MAX Beschichtung WT-Scherschliff DOWT-Scherschliff 2PT-Scherschliff 4PT-Scherschliff
Matrize	verstärkte Ausführung

*geeignet bis s = 6 mm



FINN-POWER/LVD MT8Ri1-16

Pos.-Nr. Art.-Nr. Preis in €

Stempel*			
Rund	1	413051	
Quadrat	1+4	413052	
Rechteck	1+4	413053	
Langloch	1+4	413054	
*schleifbare Kontur	1+4	41305G	
*erodierbare Kontur	1+4	41305E	

Abstreifer			
Rund	2	415051	
Quadrat	2	415052	
Rechteck	2	415053	
Langloch	2	415054	
*schleifbare Kontur	2	41505G	
*erodierbare Kontur	2	41505E	

Matrize			
Rund	3	414051	
Quadrat	3+5	414052	
Rechteck	3+5	414053	
Langloch	3+5	414054	
*schleifbare Kontur	3+5	41405G	
*erodierbare Kontur	3+5	41405E	

Werkzeug-Aufpreise:	
Stempel	TICN Beschichtung
	T-MAX Beschichtung
	WT-Scherschliff
	DOWT-Scherschliff
	2PT-Scherschliff
	4PT-Scherschliff
Matrize	verstärkte Ausführung

*geeignet bis s = 6 mm

Version 1

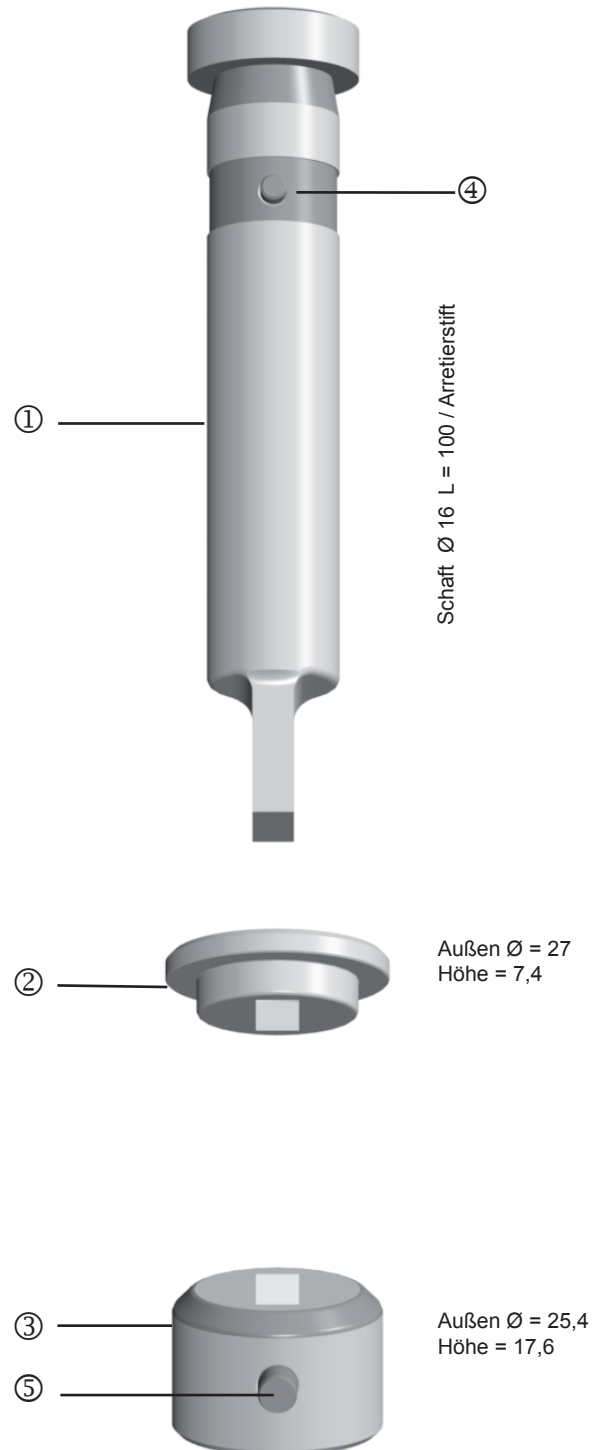



FINN-POWER/LVD MT8Ri2-16

	Pos.-Nr.	Art.-Nr.	Preis in €
Stempel*			
Rund	1	413151	
Quadrat	1	413152	
Rechteck	1	413153	
Langloch	1	413154	
*schleifbare Kontur	1	41315G	
*erodierbare Kontur	1	41315E	

Abstreifer			
Rund	2	415151	
Quadrat	2	415152	
Rechteck	2	415153	
Langloch	2	415154	
*schleifbare Kontur	2	41515G	
*erodierbare Kontur	2	41515E	

Matrize			
Rund	3	414151	
Quadrat	3+4	414152	
Rechteck	3+4	414153	
Langloch	3+4	414154	
*schleifbare Kontur	3+4	41415G	
*erodierbare Kontur	3+4	41415E	

Werkzeug-Aufpreise:	
Stempel	TICN Beschichtung T-MAX Beschichtung WT-Scherschliff DOWT-Scherschliff 2PT-Scherschliff 4PT-Scherschliff
Matrize	verstärkte Ausführung

*geeignet bis s = 6 mm

Version 2

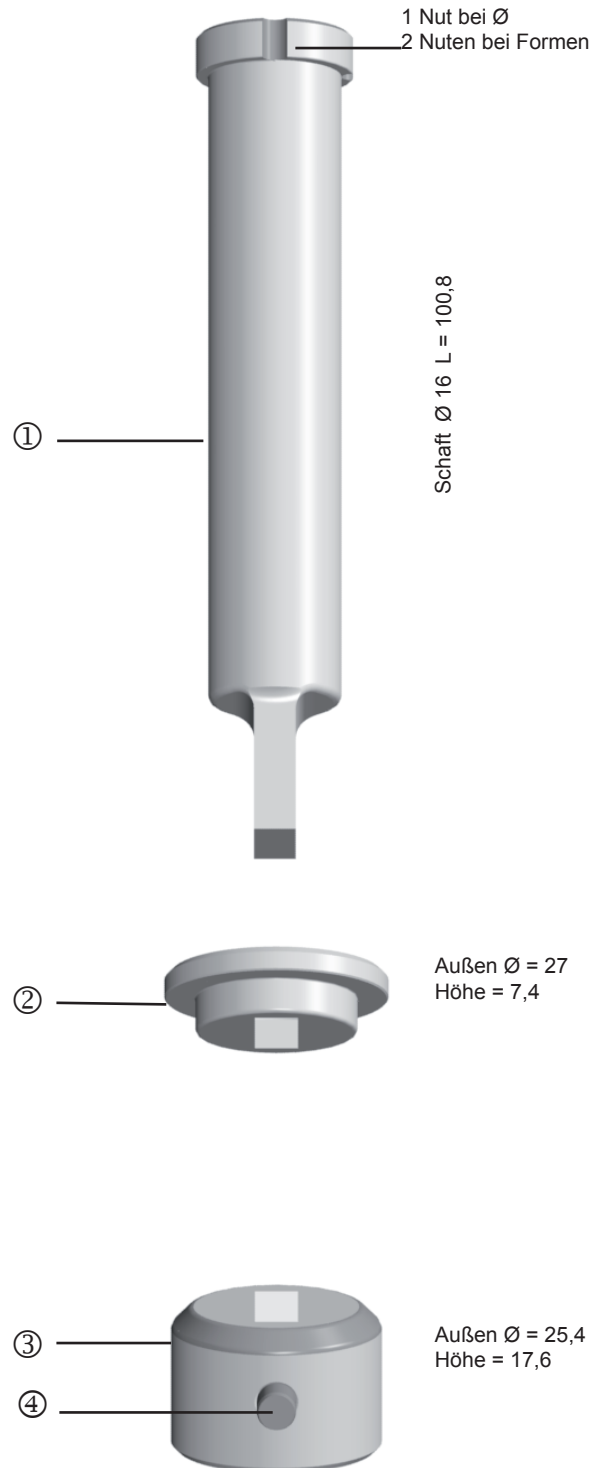



FINN-POWER/LVD

MT3Ri-31,75

MT3i-31,75

	Pos.-Nr.	Art.-Nr.	Preis in €
Stempel*			
Rund	1+4+5	413071	
Quadrat	1+4+5	413072	
Rechteck	1+4+5	413073	
Langloch	1+4+5	413074	
*schleifbare Kontur	1+4+5	41307G	
*erodierbare Kontur	1+4+5	41307E	
Abstreifer			
Rund	2	415071	
Quadrat	2	415072	
Rechteck	2	415073	
Langloch	2	415074	
*schleifbare Kontur	2	41507G	
*erodierbare Kontur	2	41507E	
Matrize			
Rund	3	414071	
Quadrat	3+6	414072	
Rechteck	3+6	414073	
Langloch	3+6	414074	
*schleifbare Kontur	3+6	41407G	
*erodierbare Kontur	3+6	41407E	

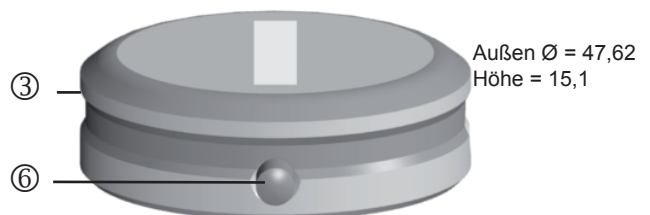
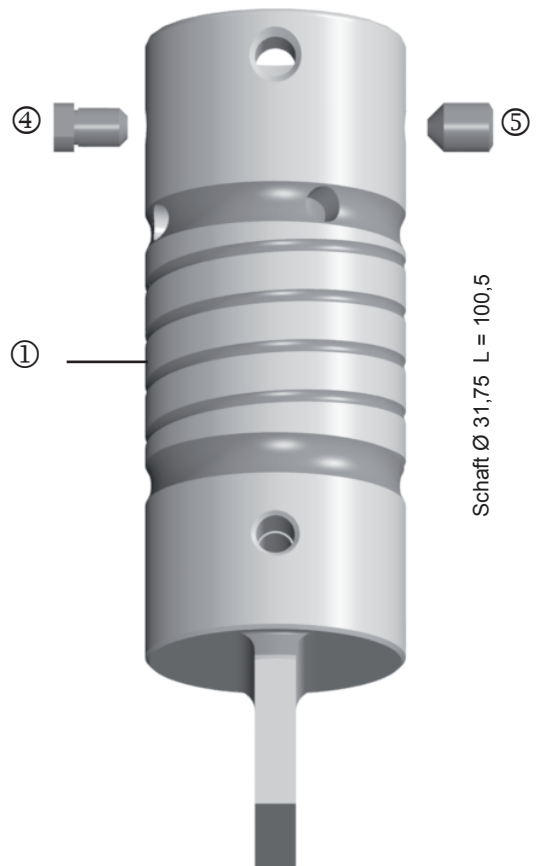

Werkzeug-Aufpreise:	
Stempel	TICN Beschichtung T-MAX Beschichtung WT-Scherschliff DOWT-Scherschliff 2PT-Scherschliff 4PT-Scherschliff
Matrize	verstärkte Ausführung

*geeignet bis s = 6 mm

System
FINN-POWER/LVD

MT24-8

MT12-8

MT20-8



	Pos.-Nr.	Art.-Nr.	Preis in €
Stempel*			
Rund	1	413121	
Quadrat	1	413122	
Rechteck	1	413123	
Langloch	1	413124	
*schleifbare Kontur	1	41312G	
*erodierbare Kontur	1	41312E	

Abstreifer			
Rund	2	415121	
Quadrat	2+4	415122	
Rechteck	2+4	415123	
Langloch	2+4	415124	
*schleifbare Kontur	2+4	41512G	
*erodierbare Kontur	2+4	41512E	

Matrize			
Rund	3	414121	
Quadrat	3+5	414122	
Rechteck	3+5	414123	
Langloch	3+5	414124	
*schleifbare Kontur	3+5	41412G	
*erodierbare Kontur	3+5	41412E	

Werkzeug-Aufpreise:

Stempel	TICN Beschichtung
	T-MAX Beschichtung
	WT-Scherschliff
	DOWT-Scherschliff
	2PT-Scherschliff
	4PT-Scherschliff
Matrize	verstärkte Ausführung

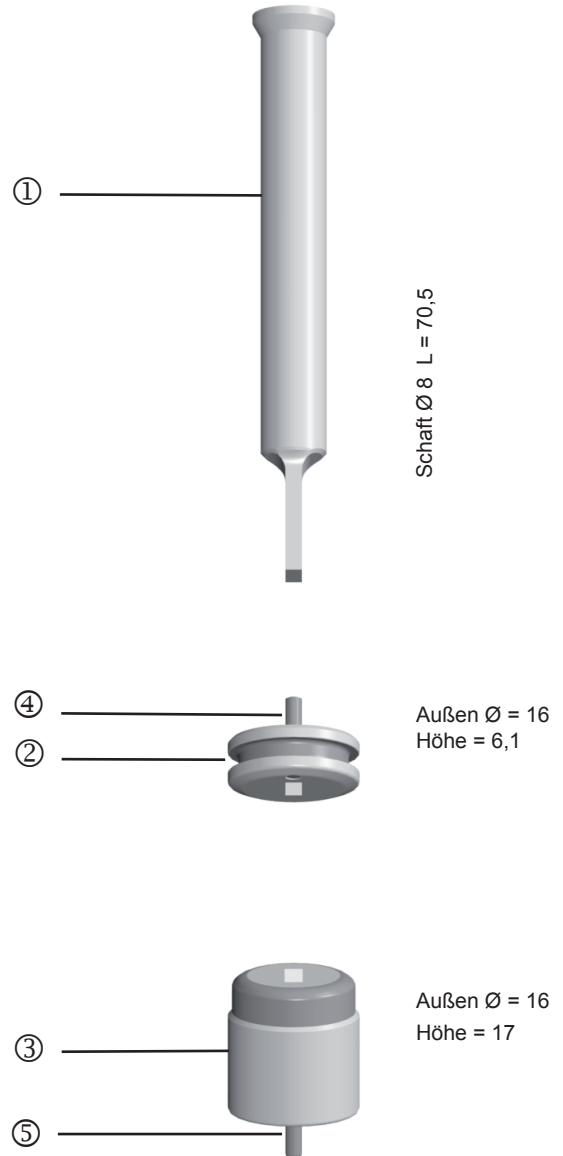

*geeignet bis s = 4 mm



FINN-POWER/LVD

MT10-16

MT6-16

	Pos.-Nr.	Art.-Nr.	Preis in €
Stempel*			
Rund	1	413021	
Quadrat	1	413022	
Rechteck	1	413023	
Langloch	1	413024	
*schleifbare Kontur	1	41302G	
*erodierbare Kontur	1	41302E	

Abstreifer			
Rund	2	415021	
Quadrat	2+4	415022	
Rechteck	2+4	415023	
Langloch	2+4	415024	
*schleifbare Kontur	2+4	41502G	
*erodierbare Kontur	2+4	41502E	

Matrize			
Rund	3	414021	
Quadrat	3+5	414022	
Rechteck	3+5	414023	
Langloch	3+5	414024	
*schleifbare Kontur	3+5	41402G	
*erodierbare Kontur	3+5	41402E	

Werkzeug-Aufpreise:	
Stempel	TICN Beschichtung T-MAX Beschichtung WT-Scherschliff DOWT-Scherschliff 2PT-Scherschliff 4PT-Scherschliff
Matrize	verstärkte Ausführung

*geeignet bis s = 4 mm

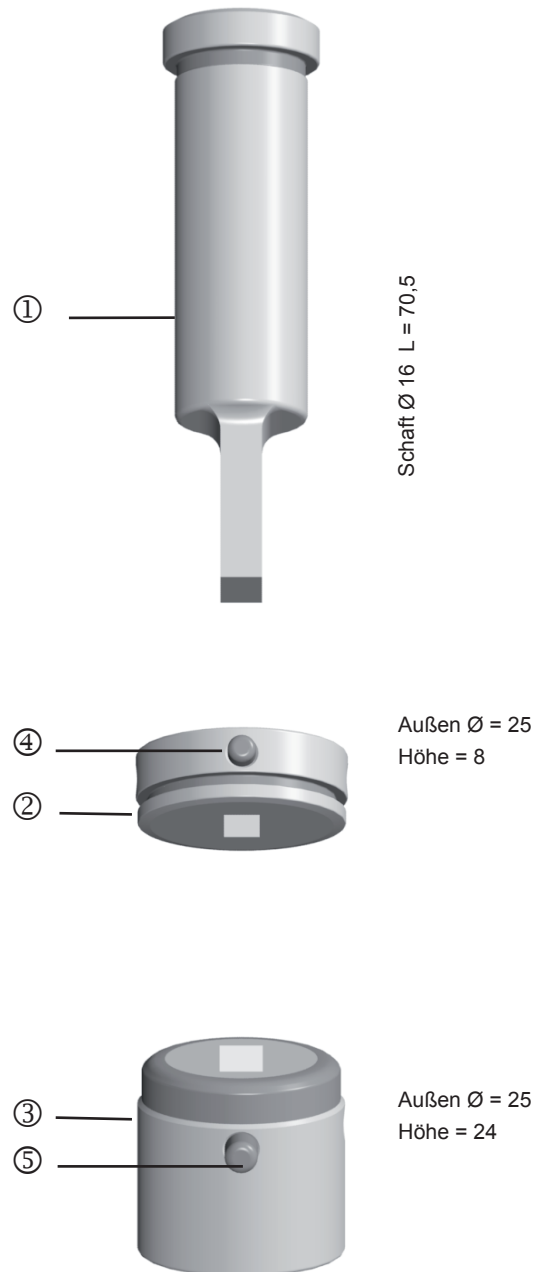



FINN-POWER/LVD MT8-24

	Pos.-Nr.	Art.-Nr.	Preis in €
Stempel*			
Rund	1	413131	
Quadrat	1	413132	
Rechteck	1	413133	
Langloch	1	413134	
*schleifbare Kontur	1	41313G	
*erodierbare Kontur	1	41313E	

Abstreifer			
Rund	2	415131	
Quadrat	2+4	415132	
Rechteck	2+4	415133	
Langloch	2+4	415134	
*schleifbare Kontur	2+4	41513G	
*erodierbare Kontur	2+4	41513E	

Matrize			
Rund	3	414131	
Quadrat	3+5	414132	
Rechteck	3+5	414133	
Langloch	3+5	414134	
*schleifbare Kontur	3+5	41413G	
*erodierbare Kontur	3+5	41413E	

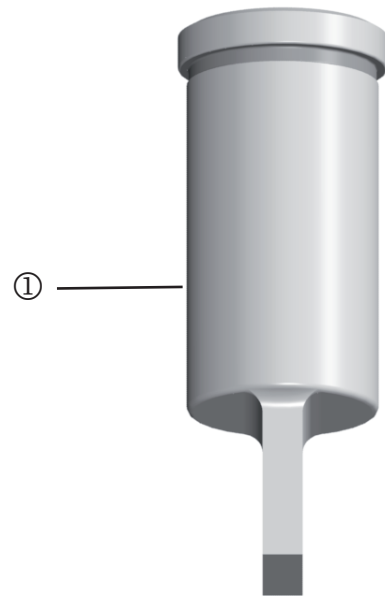

Schaft Ø 24 L = 70,5

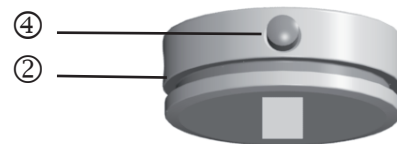

Außen Ø = 30
Höhe = 10,5

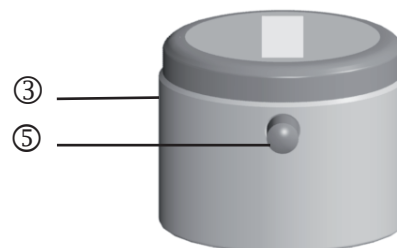

Außen Ø = 31
Höhe = 24

Werkzeug-Aufpreise:	
Stempel	TICN Beschichtung T-MAX Beschichtung WT-Scherschliff DOWT-Scherschliff 2PT-Scherschliff 4PT-Scherschliff
Matrize	verstärkte Ausführung

*geeignet bis s = 4 mm