

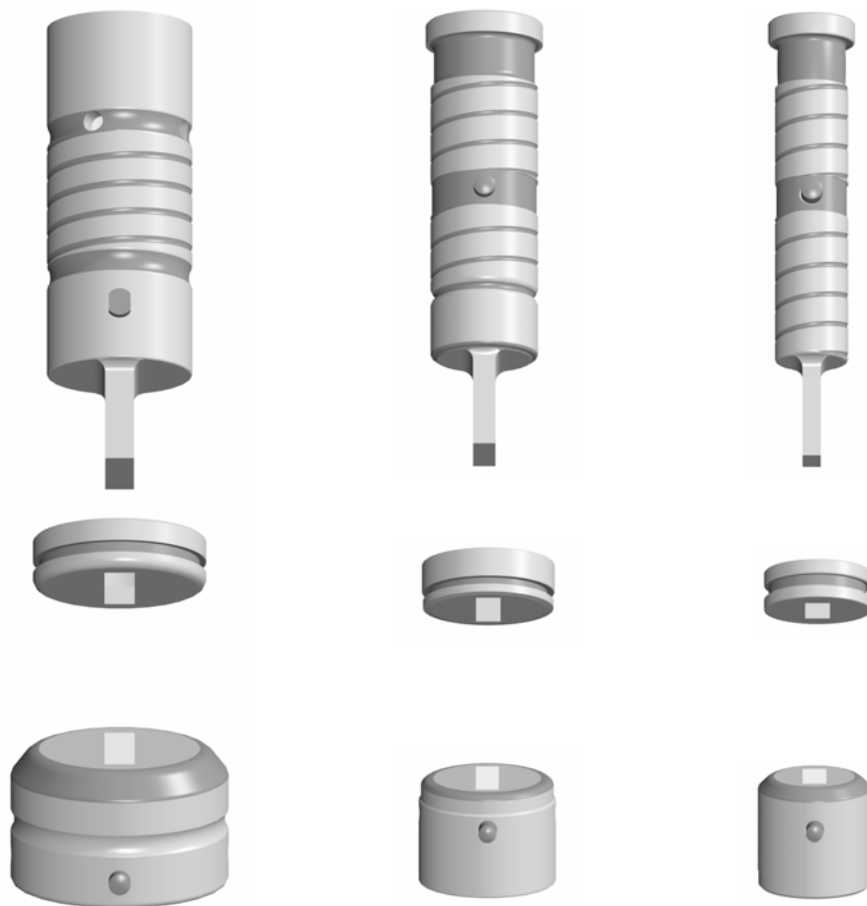

Produktübersicht 02/2010-A

Werkzeugsystem

EUROMAC Multitool





System

EUROMAC XMTE10-16

	Pos.-Nr.	Art.-Nr.
Stempel*		
Rund	1	413101
Quadrat	1+4	413102
Rechteck	1+4	413103
Langloch	1+4	413104
* schleifbare Kontur	1+4	41310G
* erodierbare Kontur	1+4	41310E

	Pos.-Nr.	Art.-Nr.
Abstreifer		
Rund	2	415101
Quadrat	2	415102
Rechteck	2	415103
Langloch	2	415104
* schleifbare Kontur	2	41510G
* erodierbare Kontur	2	41510E

	Pos.-Nr.	Art.-Nr.
Matrize		
Rund	3	414101
Quadrat	3+5	414102
Rechteck	3+5	414103
Langloch	3+5	414104
* schleifbare Kontur	3+5	41410G
* erodierbare Kontur	3+5	41410E

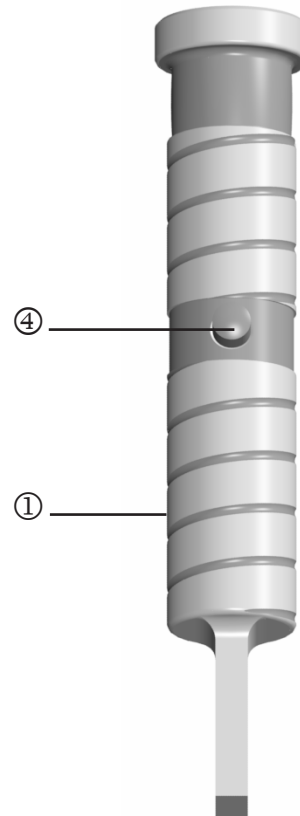

Schaft Ø 16 L = 100



Außen Ø = 19,05
Höhe = 6,9

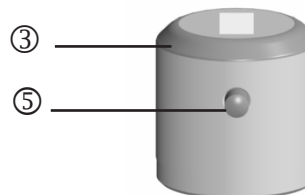

Außen Ø = 20
Höhe = 20

Werkzeug-Aufpreise

Stempel	TICN Beschichtung
	T-MAX Beschichtung
	WT-Scherschliff
	DOWT-Scherschliff
	2PT-Scherschliff
	4PT-Scherschliff
Matrize	verstärkte Ausführung

* geeignet bis s = 6 mm



System

EUROMAC XMTE6-24

	Pos.-Nr.	Art.-Nr.
Stempel*		
Rund	1	413041
Quadrat	1+4	413042
Rechteck	1+4	413043
Langloch	1+4	413044
* schleifbare Kontur	1+4	41304G
* erodierbare Kontur	1+4	41304E

	Pos.-Nr.	Art.-Nr.
Abstreifer		
Rund	2	415041
Quadrat	2	415042
Rechteck	2	415043
Langloch	2	415044
* schleifbare Kontur	2	41504G
* erodierbare Kontur	2	41504E

	Pos.-Nr.	Art.-Nr.
Matrize		
Rund	3	414041
Quadrat	3+5	414042
Rechteck	3+5	414043
Langloch	3+5	414044
* schleifbare Kontur	3+5	41404G
* erodierbare Kontur	3+5	41404E

Werkzeug-Aufpreise	
Stempel	TICN Beschichtung
	T-MAX Beschichtung
	WT-Scherschliff
	DOWT-Scherschliff
	2PT-Scherschliff
	4PT-Scherschliff
Matrize	verstärkte Ausführung

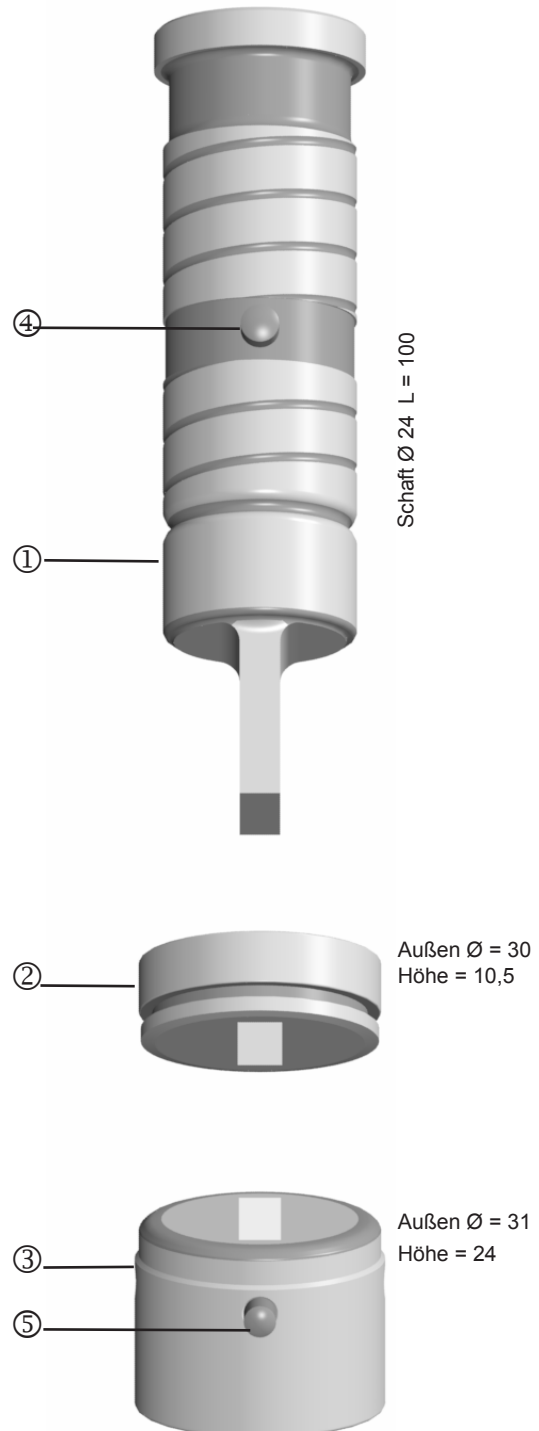

* geeignet bis s = 6 mm



System

EUROMAC XMTE4-31,75

	Pos.-Nr.	Art.-Nr.
Stempel*		
Rund	1	413141
Quadrat	1+4	413142
Rechteck	1+4	413143
Langloch	1+4	413144
* schleifbare Kontur	1+4	41314G
* erodierbare Kontur	1+4	41314E

Abstreifer		
Rund	2	415141
Quadrat	2	415142
Rechteck	2	415143
Langloch	2	415144
* schleifbare Kontur	2	41514G
* erodierbare Kontur	2	41514E

Matrize		
Rund	3	414141
Quadrat	3+5	414142
Rechteck	3+5	414143
Langloch	3+5	414144
* schleifbare Kontur	3+5	41414G
* erodierbare Kontur	3+5	41414E

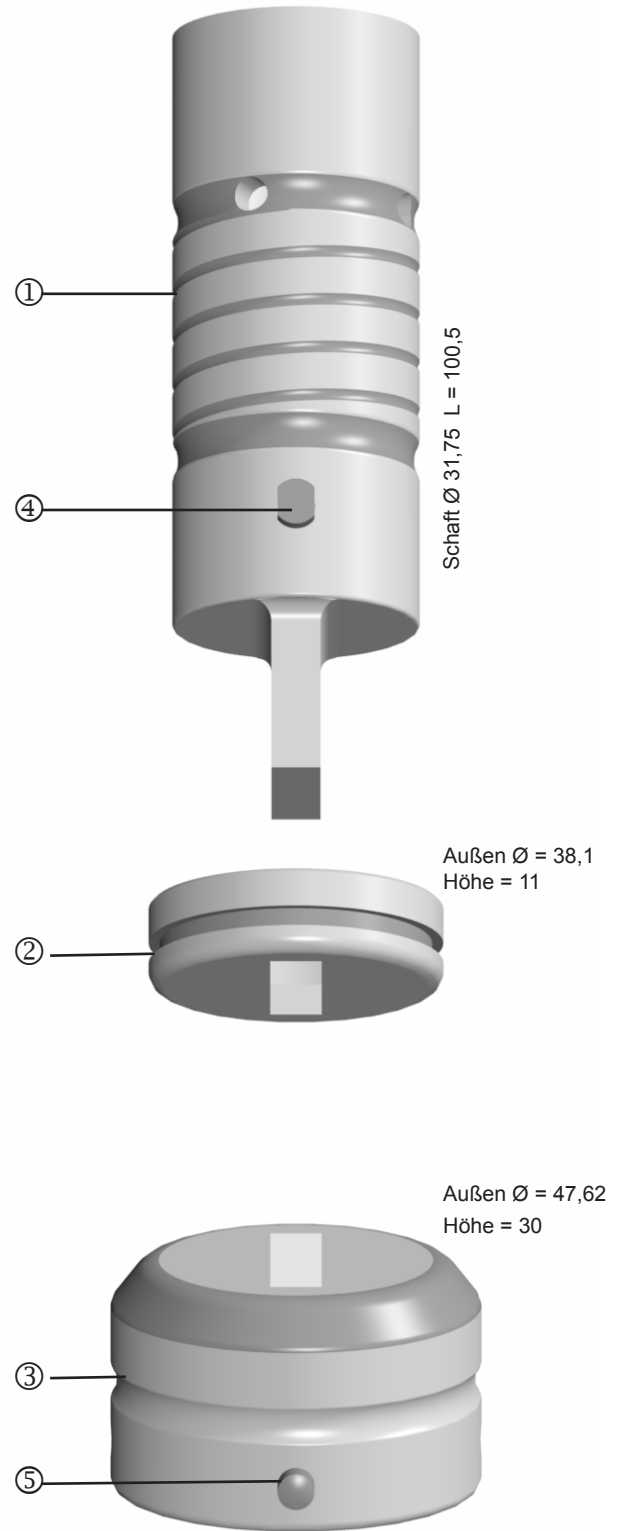

Werkzeug-Aufpreise	
Stempel	TICN Beschichtung T-MAX Beschichtung WT-Scherschliff DOWT-Scherschliff 2PT-Scherschliff 4PT-Scherschliff
Matrize	verstärkte Ausführung

* geeignet bis s = 6 mm



System

EUROMAC

MTE10-8

(Pos. 2/3/4/5/6/8/10)

	Pos.-Nr.	Art.-Nr.
Stempel*		
Rund	1	413011
Quadrat	1	413012
Rechteck	1	413013
Langloch	1	413014
* schleifbare Kontur	1	41301G
* erodierbare Kontur	1	41301E

Abstreifer		
Rund	2	415011
Quadrat	2+4	415012
Rechteck	2+4	415013
Langloch	2+4	415014
* schleifbare Kontur	2+4	41501G
* erodierbare Kontur	2+4	41501E

Matrize		
Rund	3	414011
Quadrat	3+5	414012
Rechteck	3+5	414013
Langloch	3+5	414014
* schleifbare Kontur	3+5	41401G
* erodierbare Kontur	3+5	41401E

Werkzeug-Aufpreise

Stempel	TICN Beschichtung
	T-MAX Beschichtung
	WT-Scherschliff
	DOWT-Scherschliff
	2PT-Scherschliff
	4PT-Scherschliff
Matrize	verstärkte Ausführung

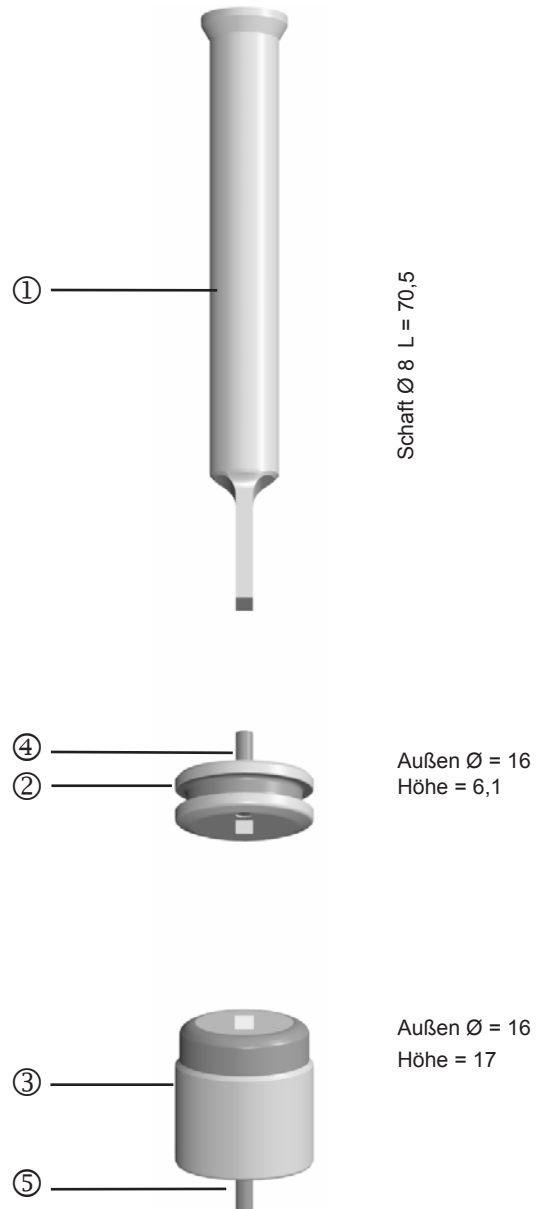

* geeignet bis s = 4 mm



System

EUROMAC

MTE 6-24

MTE 10-24 (Pos. 1/7/9)

	Pos.-Nr.	Art.-Nr.
Stempel*		
Rund	1	413031
Quadrat	1	413032
Rechteck	1	413033
Langloch	1	413034
* schleifbare Kontur	1	41303G
* erodierbare Kontur	1	41303E

Abstreifer		
Rund	2	415031
Quadrat	2+4	415032
Rechteck	2+4	415033
Langloch	2+4	415034
* schleifbare Kontur	2+4	41503G
* erodierbare Kontur	2+4	41503E

Matrize		
Rund	3	414031
Quadrat	3+5	414032
Rechteck	3+5	414033
Langloch	3+5	414034
* schleifbare Kontur	3+5	41403G
* erodierbare Kontur	3+5	41403E

Werkzeug-Aufpreise	
Stempel	TICN Beschichtung T-MAX Beschichtung WT-Scherschliff DOWT-Scherschliff 2PT-Scherschliff 4PT-Scherschliff
Matrize	verstärkte Ausführung

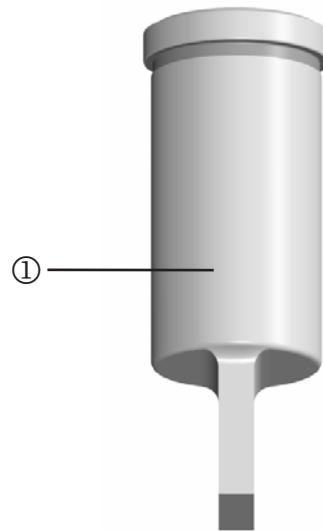

Schaft Ø 24 L = 70,5

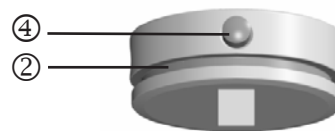

Außen Ø = 30
Höhe = 10,5

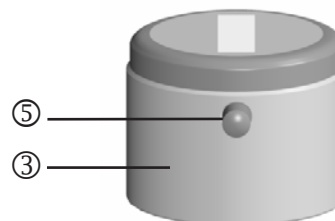

Außen Ø = 31
Höhe = 24

* geeignet bis s = 4 mm



System

EUROMAC MTE4-31,75

	Pos.-Nr.	Art.-Nr.
Stempel*		
Rund	1	413061
Quadrat	1+4	413062
Rechteck	1+4	413063
Langloch	1+4	413064
* schleifbare Kontur	1+4	41306G
* erodierbare Kontur	1+4	41306E

Abstreifer		
Rund	2	415061
Quadrat	2	415062
Rechteck	2	415063
Langloch	2	415064
* schleifbare Kontur	2	41506G
* erodierbare Kontur	2	41506E

Matrize		
Rund	3	414061
Quadrat	3+5	414062
Rechteck	3+5	414063
Langloch	3+5	414064
* schleifbare Kontur	3+5	41406G
* erodierbare Kontur	3+5	41406E

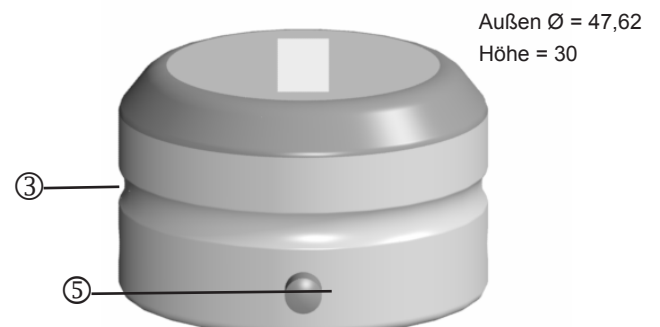
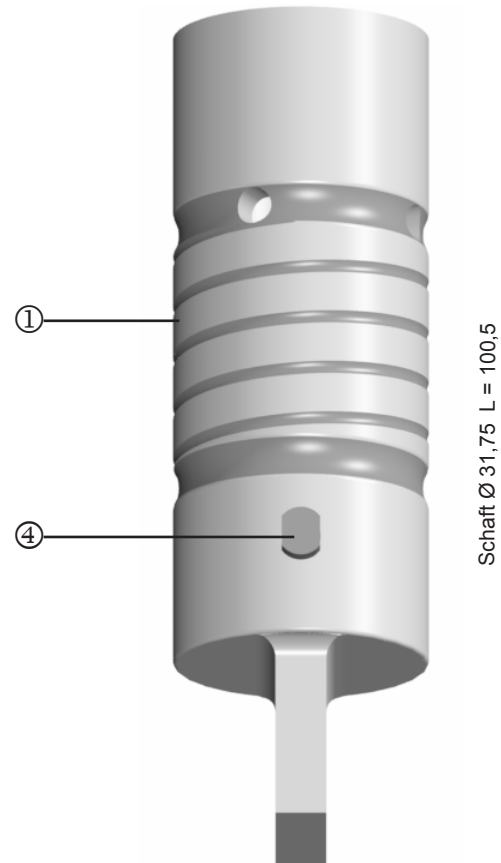

Werkzeug-Aufpreise

Stempel	TICN Beschichtung
	T-MAX Beschichtung
	WT-Scherschliff
	DOWT-Scherschliff
	2PT-Scherschliff
	4PT-Scherschliff
Matrize	verstärkte Ausführung

* geeignet bis s = 6 mm

