

Productlist 02/2010-A

Tooling System

EUROMAC

Multitool

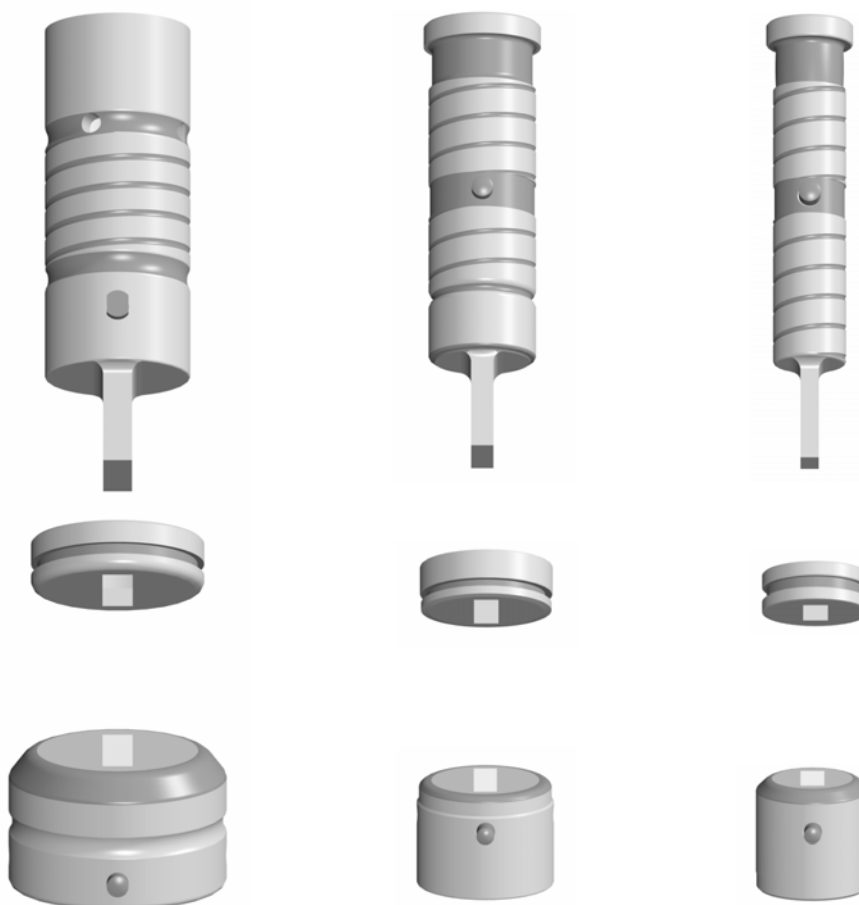



System

EUROMAC XMTE10-16

	Pos.-No.	Part-No.
Punch*		
Round	1	413101
Square	1+4	413102
Rectangular	1+4	413103
Oblong	1+4	413104
* O.D.Ground Special Shape	1+4	41310G
* EDM required Special Shape	1+4	41310E

Punch		
Round	2	415101
Square	2	415102
Rectangular	2	415103
Oblong	2	415104
* O.D.Ground Special Shape	2	41510G
* EDM required Special Shape	2	41510E

Die		
Round	3	414101
Square	3+5	414102
Rectangular	3+5	414103
Oblong	3+5	414104
* O.D.Ground Special Shape	3+5	41410G
* EDM required Special Shape	3+5	41410E

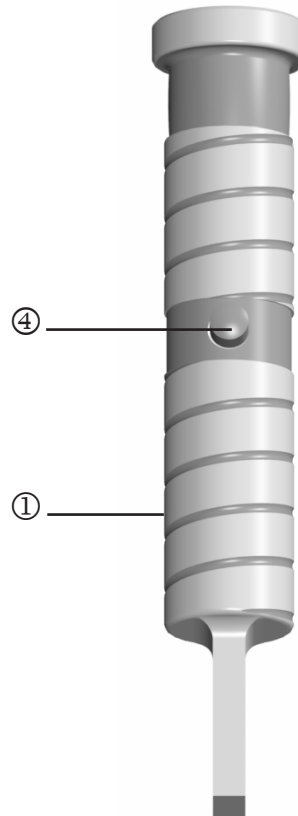

Shank Ø 16 L = 100



Outer Ø = 19,05
Height = 6,9

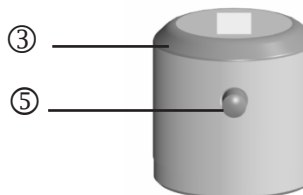

Outer Ø = 20
Height = 20

Additional tool costs

Punch	TICN Coating
	T-MAX Coating
	WT-Shear
	DOWT-Shear
	2PT-Shear
	4PT-Shear
Die	reinforced version

* suitable up to s = 6 mm



System

EUROMAC XMTE6-24

	Pos.-No.	Part.-No.
Punch*		
Round	1	413041
Square	1+4	413042
Rectangular	1+4	413043
Oblong	1+4	413044
* O.D.Ground Special Shape	1+4	41304G
* EDM required Special Shape	1+4	41304E
Stripper		
Round	2	415041
Square	2	415042
Rectangular	2	415043
Oblong	2	415044
* O.D.Ground Special Shape	2	41504G
* EDM required Special Shape	2	41504E
Die		
Round	3	414041
Square	3+5	414042
Rectangular	3+5	414043
Oblong	3+5	414044
* O.D.Ground Special Shape	3+5	41404G
* EDM required Special Shape	3+5	41404E

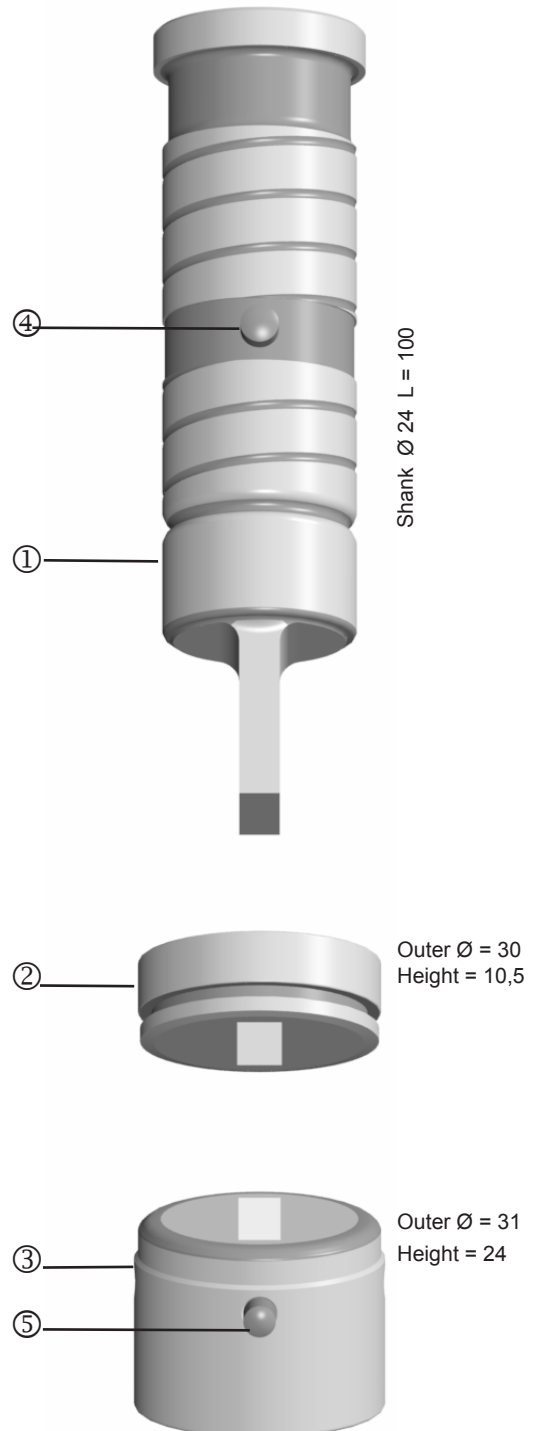

Additional tool costs	
Punch	TICN Coating T-MAX Coating WT-Shear DOWT-Shear 2PT-Shear 4PT-Shear
Die	reinforced version

* suitable up to s = 6 mm



System

EUROMAC XMTE4-31,75

	Pos.-No.	Part.-No.
Punch*		
Round	1	413141
Square	1+4	413142
Rectangular	1+4	413143
Oblong	1+4	413144
* O.D.Ground Special Shape	1+4	41314G
* EDM required Special Shape	1+4	41314E
Stripper		
Round	2	415141
Square	2	415142
Rectangular	2	415143
Oblong	2	415144
* O.D.Ground Special Shape	2	41514G
* EDM required Special Shape	2	41514E
Die		
Round	3	414141
Square	3+5	414142
Rectangular	3+5	414143
Oblong	3+5	414144
* O.D.Ground Special Shape	3+5	41414G
* EDM required Special Shape	3+5	41414E

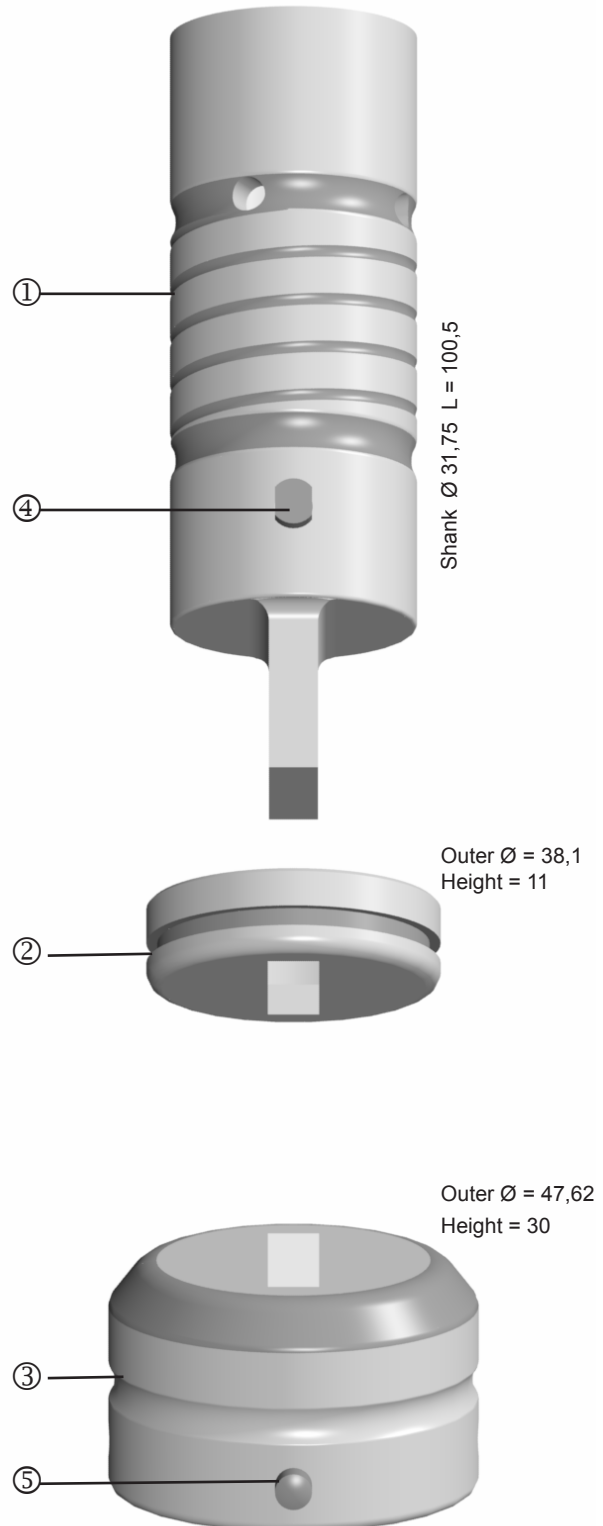

Additional tool costs

Punch	TICN Coating
	T-MAX Coating
	WT-Shear
	DOWT-Shear
	2PT-Shear
	4PT-Shear
Die	reinforced version

* suitable up to s = 6 mm



System

EUROMAC

MTE10-8

(Pos. 2/3/4/5/6/8/10)

	Pos.-No.	Part.-No
Punch*		
Round	1	413011
Square	1	413012
Rectangular	1	413013
Oblong	1	413014
* O.D.Ground Special Shape	1	41301G
* EDM required Special Shape	1	41301E

	Pos.-No.	Part.-No
Stripper		
Round	2	415011
Square	2+4	415012
Rectangular	2+4	415013
Oblong	2+4	415014
* O.D.Ground Special Shape	2+4	41501G
* EDM required Special Shape	2+4	41501E

	Pos.-No.	Part.-No
Die		
Round	3	414011
Square	3+5	414012
Rectangular	3+5	414013
Oblong	3+5	414014
* O.D.Ground Special Shape	3+5	41401G
* EDM required Special Shape	3+5	41401E

Additional tool costs

Punch	TICN Coating
	T-MAX Coating
	WT-Shear
	DOWT-Shear
	2PT-Shear
	4PT-Shear
Die	reinforced version

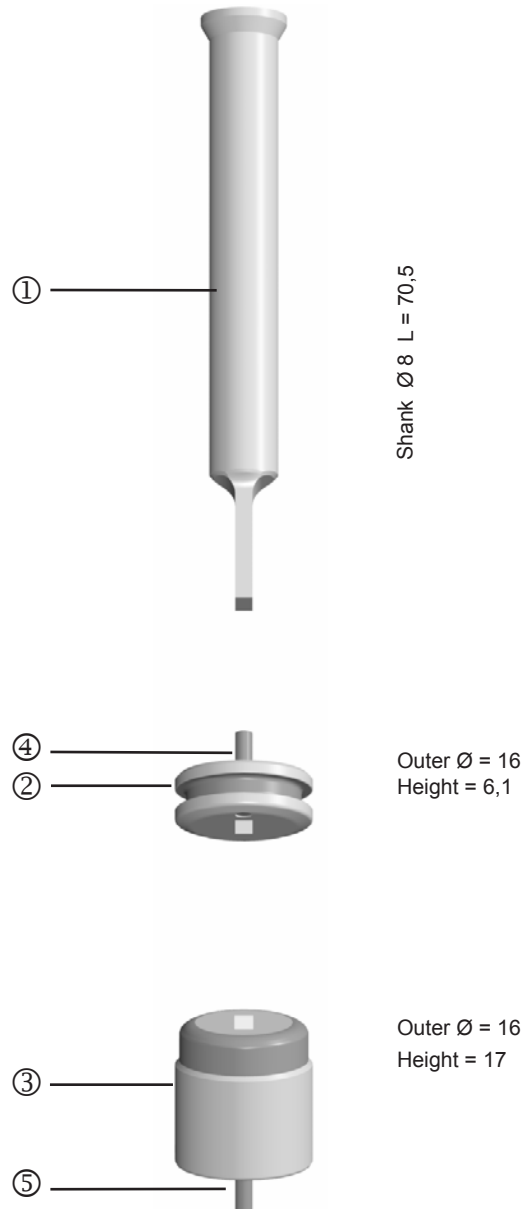

* suitable up to s = 4 mm



System

EUROMAC

MTE 6-24

MTE 10-24 (Pos. 1/7/9)

	Pos.-No.	Part.-No.
Punch*		
Round	1	413031
Square	1	413032
Rectangular	1	413033
Oblong	1	413034
* O.D.Ground Special Shape	1	41303G
* EDM required Special Shape	1	41303E

	Pos.-No.	Part.-No.
Stripper		
Round	2	415031
Square	2+4	415032
Rectangular	2+4	415033
Oblong	2+4	415034
* O.D.Ground Special Shape	2+4	41503G
* EDM required Special Shape	2+4	41503E

	Pos.-No.	Part.-No.
Die		
Round	3	414031
Square	3+5	414032
Rectangular	3+5	414033
Oblong	3+5	414034
* O.D.Ground Special Shape	3+5	41403G
* EDM required Special Shape	3+5	41403E

Additional tool costs

Punch	TICN Coating
	T-MAX Coating
	WT-Shear
	DOWT-Shear
	2PT-Shear
	4PT-Shear
Die	reinforced version

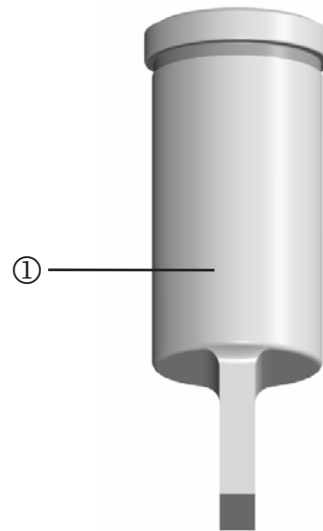

Shank Ø 24 L = 70,5

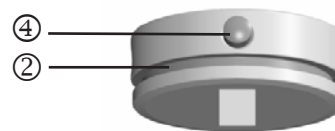

Outer Ø = 30
Height = 10,5

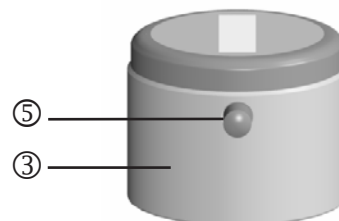

Outer Ø = 31
Height = 24

* suitable up to s = 4 mm



System

EUROMAC MTE4-31,75

	Pos.-No.	Part.-No.
Punch*		
Round	1	413061
Square	1+4	413062
Rectangular	1+4	413063
Oblong	1+4	413064
* O.D.Ground Special Shape	1+4	41306G
* EDM required Special Shape	1+4	41306E

	Pos.-No.	Part.-No.
Stripper		
Round	2	415061
Square	2	415062
Rectangular	2	415063
Oblong	2	415064
* O.D.Ground Special Shape	2	41506G
* EDM required Special Shape	2	41506E

	Pos.-No.	Part.-No.
Die		
Round	3	414061
Square	3+5	414062
Rectangular	3+5	414063
Oblong	3+5	414064
* O.D.Ground Special Shape	3+5	41406G
* EDM required Special Shape	3+5	41406E

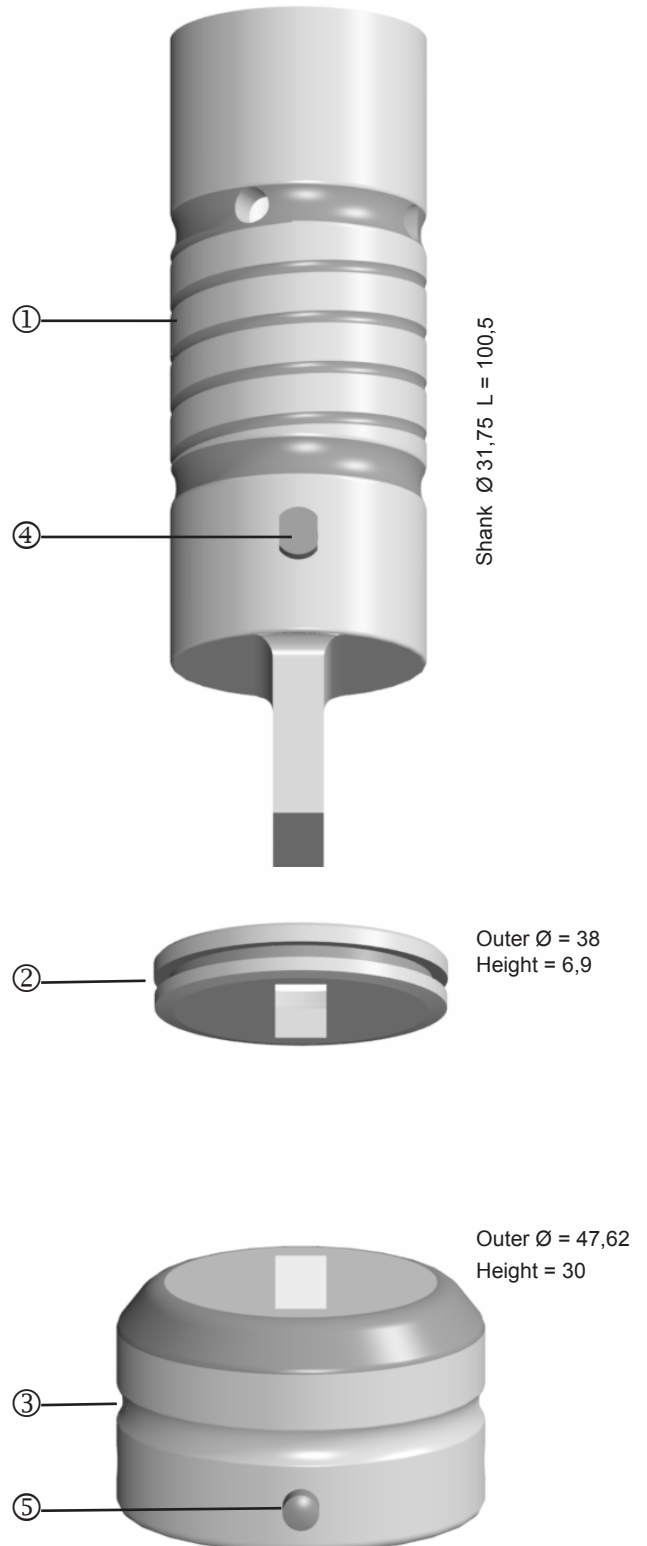

Additional tool costs	
Punch	TICN Coating T-MAX Coating WT-Shear DOWT-Shear 2PT-Shear 4PT-Shear
Die	reinforced version

* suitable up to s = 6 mm

