

ENDLOS-SICKENWERKZEUG

CONTINUOUS BEADING TOOL

TRUMPF

THICK TURRET

SALVAGNINI

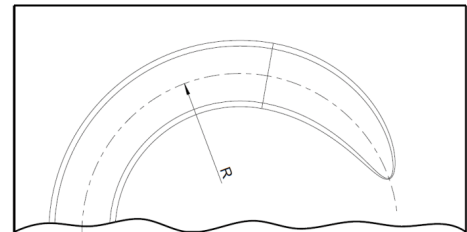
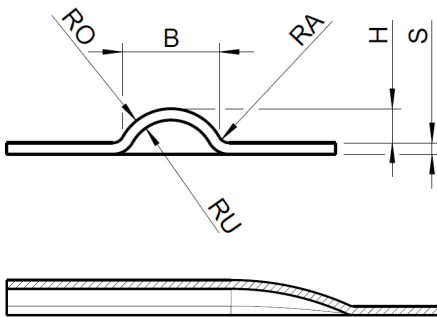

Vorschub / Hub \approx 1 - 5 mm / Tool distance / stroke \approx 1 - 5 mm

Für eine optimale Umformung empfehlen wir $B_{min} = 3 \times H$ / We advice $B_{min} = 3 \times H$ for an optimum forming

BASISINFORMATIONEN / BASIC INFORMATION

Material:	
Blechstärke „s“ / Sheet thickness „s“:	
Maschine / Machine:	
Größe / Station Size / station:	
Umformrichtung / Direction of forming:	nach oben / upform <input type="checkbox"/>
	nach unten / downform <input type="checkbox"/>
Kundendaten / Customer information:	

WERKZEUGANGABEN / TOOL INFORMATION IN MM

B:	
RO:	
RU:	
RA:	
H:	
Sickenform / Beading shape:	
Gerade / Straight <input type="checkbox"/>	Kreisbogen / Circular <input type="checkbox"/>
R:	

Bestellvorlagen_Sonderwerkzeuge 05/2021 Version 2.1