

WHEEL TOOLS: ps:® wheel

FOR MACHINE TYPES TRUMPF, THICK TURRET & SALVAGNINI

- for different range of applications (e.g. beading-, flange- or offset-tool)
- reduced warpage because of differential effect (segmented wheels)
- no chatter marks
- integrated lubrication
- working with close radius possible
- perfect operating characteristics due to the shafts coated with a special lubrication
- dimensions according to customer requirements
- for different sheet materials and thicknesses

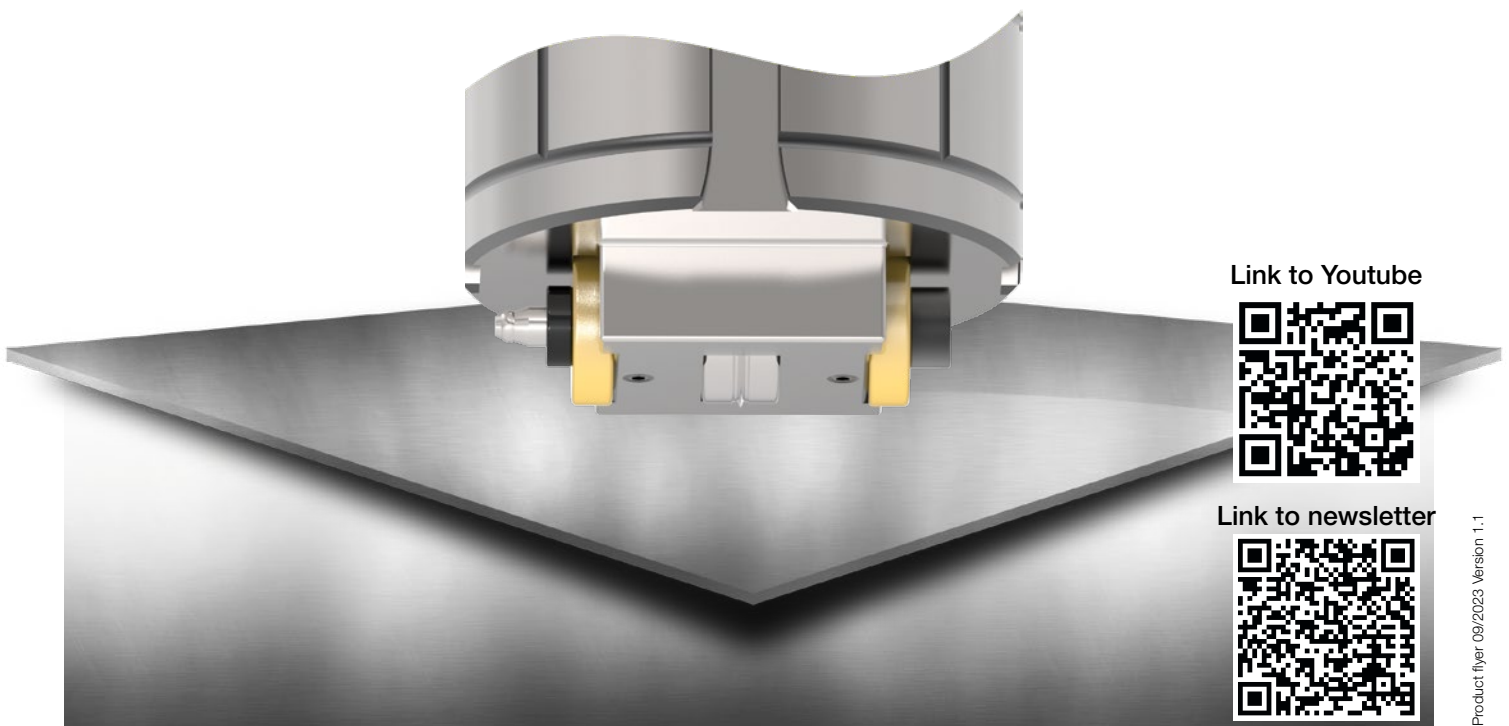
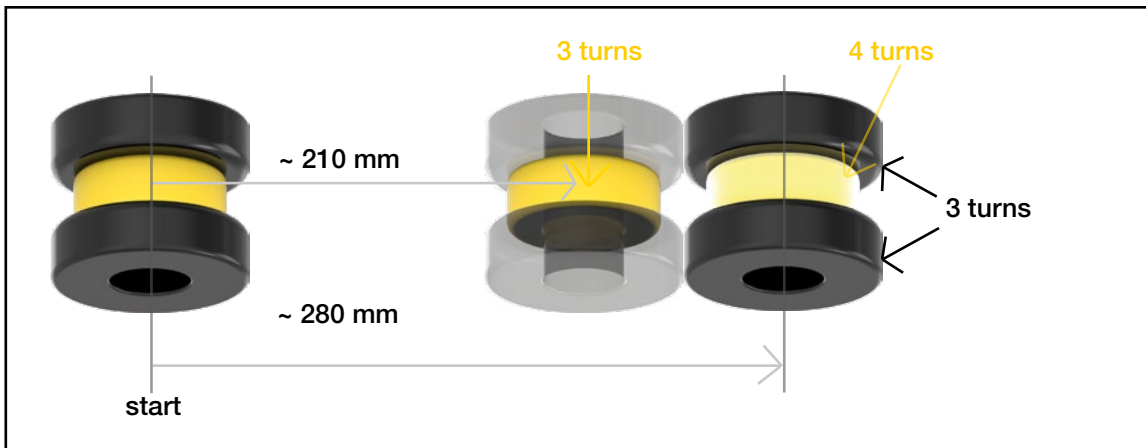

Link to Youtube



Link to newsletter



TRUMPF

THICK TURRET

SALVAGNINI

Product flyer 09/2023 Version 1.1