

CONTINUOUS BEADING TOOL

ENDLOS-SICKENWERKZEUG

TRUMPF
THICK TURRET
SALVAGNINI

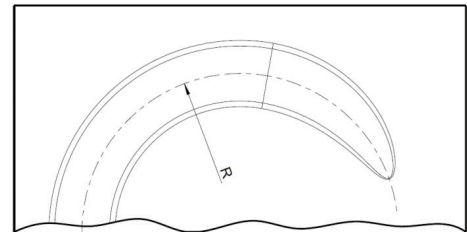
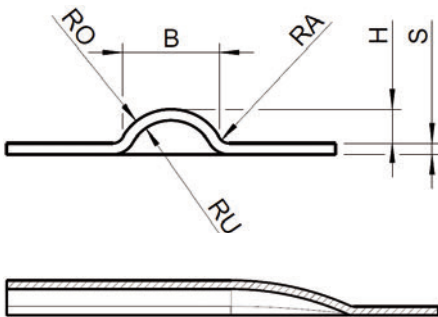

Tool distance / stroke $\approx 1 - 5$ mm / Vorschub / Hub $\approx 1 - 5$ mm

We advice $B_{min} = 3 \times H$ for an optimum forming / Für eine optimale Umformung empfehlen wir $B_{min} = 3 \times H$

BASIC INFORMATION / BASISINFORMATIONEN

Material:	
Sheet thickness „s“ / Blechstärke „s“:	
Machine / Maschine:	
Size / station Größe / Station:	
Direction of forming / Umformrichtung:	upform / nach oben <input type="checkbox"/>
	downform / nach unten <input type="checkbox"/>
Customer information / Kundendaten	

TOOL INFORMATION / WERKZEUGANGABEN IN MM

B:	
RO:	
RU:	
RA:	
H:	
Beading shape / Sickenform:	
Straight / Gerade <input type="checkbox"/>	Circular / Kreisbogen <input type="checkbox"/>
R:	

Order_ferms_Special_Tools 04/2020 Version 2.0