

# COUNTERSINK TOOL

## SENKWERKZEUG

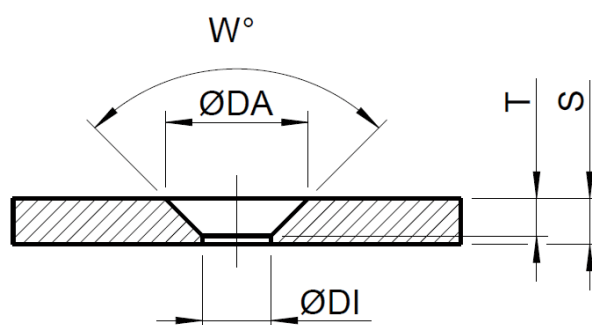

TRUMPF

THICK TURRET

SALVAGNINI

	90°-SINKING / 90°-SENKUNG		120°-SINKING / 120°-SENKUNG	
	min. cyl. part / min. zyl. Anteil	max. sinking depth / max. Senktiefe	min. cyl. part / min. zyl. Anteil	max. sinking depth / max. Senktiefe
Aluminium / Alublech	0.25 mm	90 % of s / 90% von s	0.35 mm	80 % of s / 80 % von s
Steel / Stahlblech	0.25 mm	80 % of s / 80 % von s	0.35 mm	70 % of s / 70 % von s
Stainless steel / Edelstahl-Blech	0.5 mm	66 % of s / 66 % von s	0.7 mm	50 % of s / 50 % von s

### BASIC INFORMATION / BASISINFORMATIONEN

Material:	
Sheet thickness „s“ / Blechstärke „s“:	
Machine / Maschine:	
Size / station Größe / Station:	
Direction of forming / Umformrichtung:	upform / nach oben <input type="checkbox"/>
	downform / nach unten <input type="checkbox"/>
Customer information / Kundendaten:	

### TOOL INFORMATION / WERKZEUGANGABEN IN MM

øDA:			
øDI:			
W in °:			
T:			
<input type="checkbox"/> DIN			
M2 <input type="checkbox"/>	M2.5 <input type="checkbox"/>	M3 <input type="checkbox"/>	M4 <input type="checkbox"/>
M5 <input type="checkbox"/>	M5.5 <input type="checkbox"/>	M6 <input type="checkbox"/>	M8 <input type="checkbox"/>
ST2.2 <input type="checkbox"/>	ST2.9 <input type="checkbox"/>	ST3.5 <input type="checkbox"/>	ST4.2 <input type="checkbox"/>
ST4.8 <input type="checkbox"/>	ST5.5 <input type="checkbox"/>	ST6.3 <input type="checkbox"/>	ST8 <input type="checkbox"/>

Order\_forms\_Special\_Tools 04/2020 Version 2.0