

ps:[®]pivot

FOR TRUE 90° BENDS

- for sheet materials
aluminium, steel, stainless steel
- height of tab is limited by machine
type (e.g. TRUMPF machines up to
22,0 mm tab height)
- tab widths up to 55,0 mm
- even slight overbending (approx.
91-93°) is possible
- programming as embossing tool or
with "Multibend" function required
- for sheet thickness $s = 0,8$ up to
1,5 mm (aluminium and steel up to
2,0 mm)

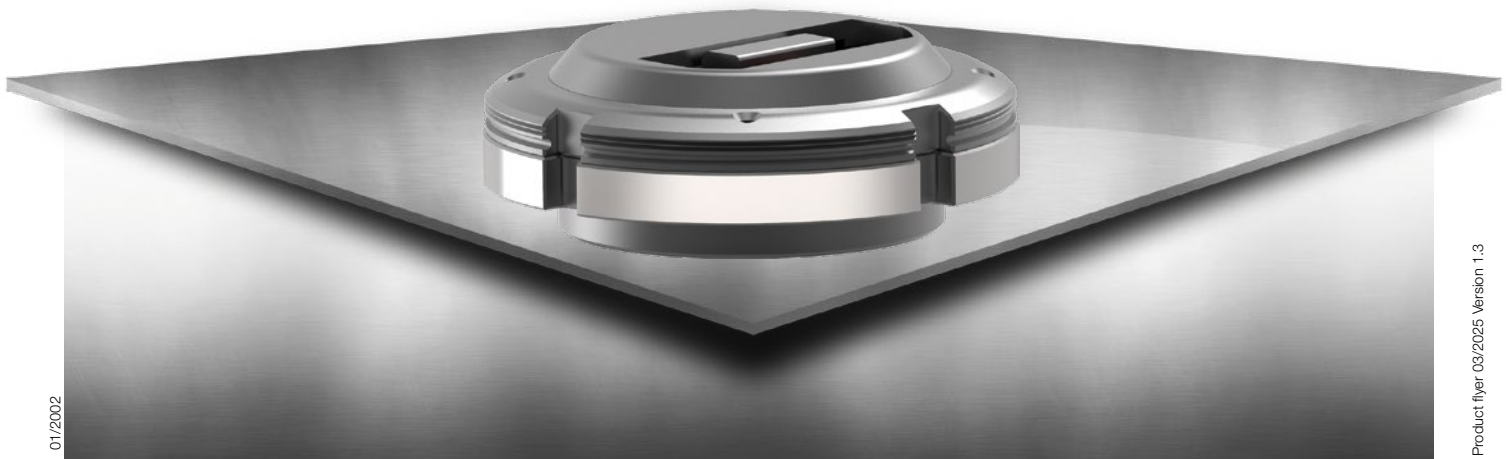
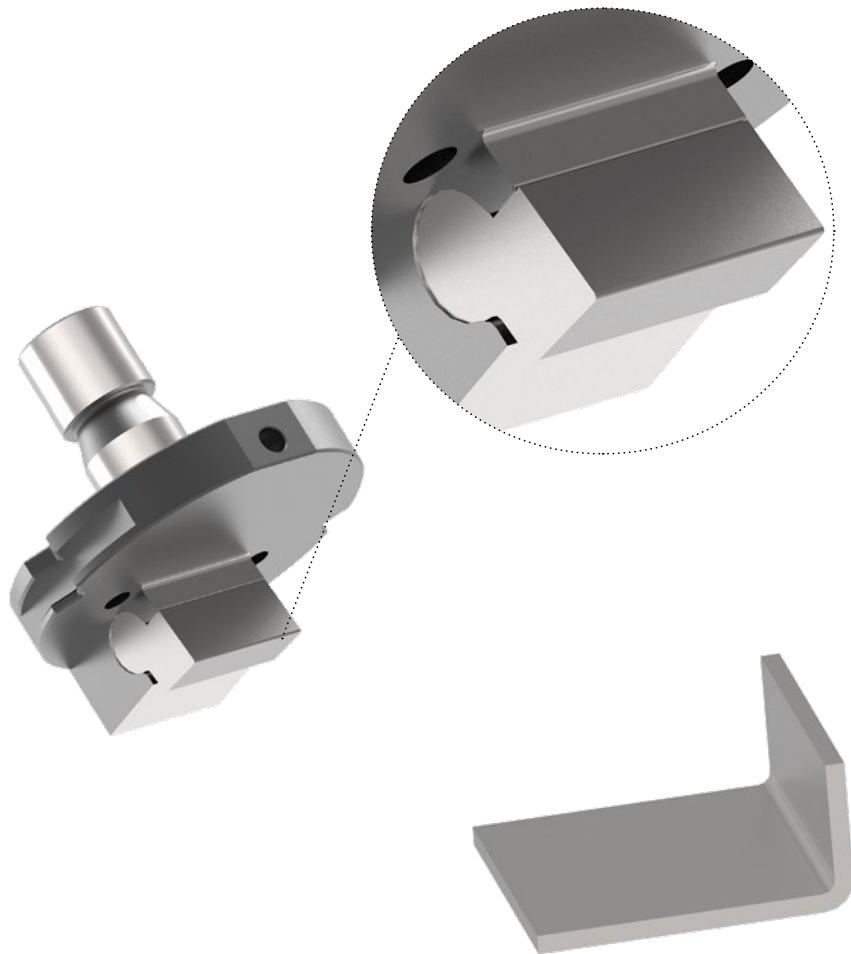

TRUMPF

THICK TURRET

SALVAGNINI